



US 20150249117A1

(19) **United States**

(12) **Patent Application Publication**

Choi et al.

(10) **Pub. No.: US 2015/0249117 A1**

(43) **Pub. Date: Sep. 3, 2015**

(54) **ORGANIC LIGHT EMITTING DIODE DISPLAY DEVICE AND METHOD OF FABRICATING THE SAME**

Publication Classification

(71) Applicant: **LG DISPLAY CO., LTD.**, Seoul (KR)

(51) **Int. Cl.**
H01L 27/32 (2006.01)
H01L 51/50 (2006.01)

(72) Inventors: **Dae-Jung Choi**, Paju-si (KR); **Jae-Ki Lee**, Paju-si (KR); **Ki-Soub Yang**, Paju-si (KR); **Hwang-Un Seo**, Paju-si (KR); **Hong-Myeong Jeon**, Goyang-si (KR); **Seung-Ryul Choi**, Goyang-si (KR); **A-Ryoung Lee**, Seoul (KR); **Han-Hee Kim**, Anseong-si (KR); **Geum-Young Lee**, Incheon (KR); **Kang-Hyun Kim**, Gyeongju-si (KR)

(52) **U.S. Cl.**
CPC *H01L 27/3246* (2013.01); *H01L 51/5012* (2013.01); *H01L 27/3248* (2013.01); *H01L 27/3262* (2013.01)

(21) Appl. No.: **14/643,714**

(57) **ABSTRACT**

(22) Filed: **Mar. 10, 2015**

An organic light emitting diode display device includes a substrate including a display region, wherein a plurality of pixel regions are defined in the display region; a first electrode over the substrate and in each of the plurality of pixel regions; a bank including a lower layer and an upper layer on the first electrode, the lower layer disposed on edges of the first electrode and having a first width and a first thickness, the upper layer disposed on the lower layer and having a second width smaller than the first width; an organic emitting layer on the first electrode and a portion of the lower layer; and a second electrode on the organic emitting layer and covering an entire surface of the display region.

Related U.S. Application Data

(62) Division of application No. 14/012,321, filed on Aug. 28, 2013.

Foreign Application Priority Data

Nov. 26, 2012 (KR) 10-2012-0134299

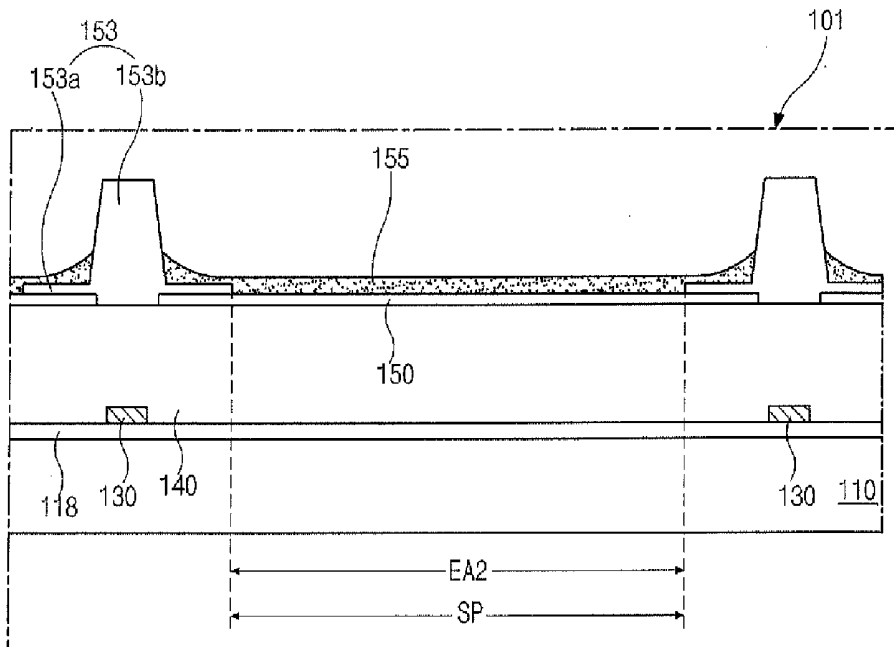

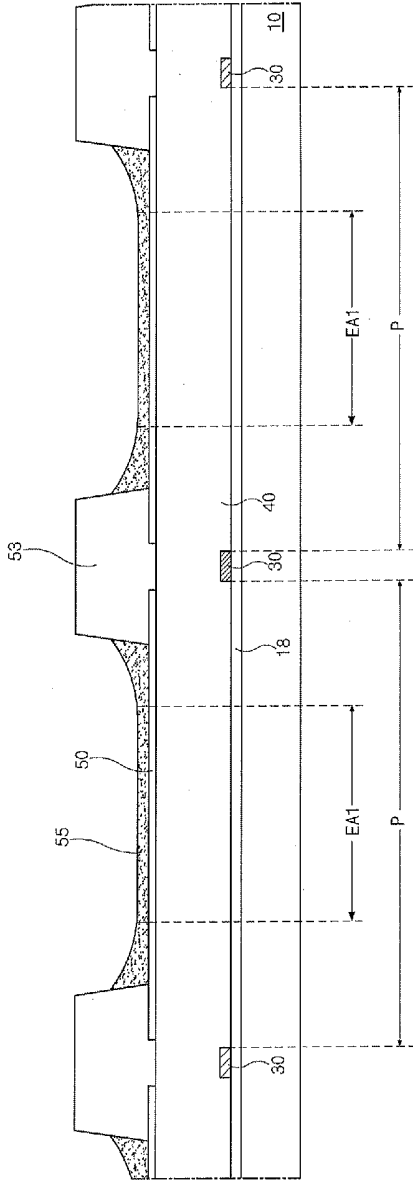

FIG. 1
Prior Art

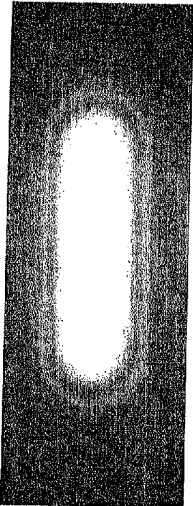

FIG. 2
Prior Art

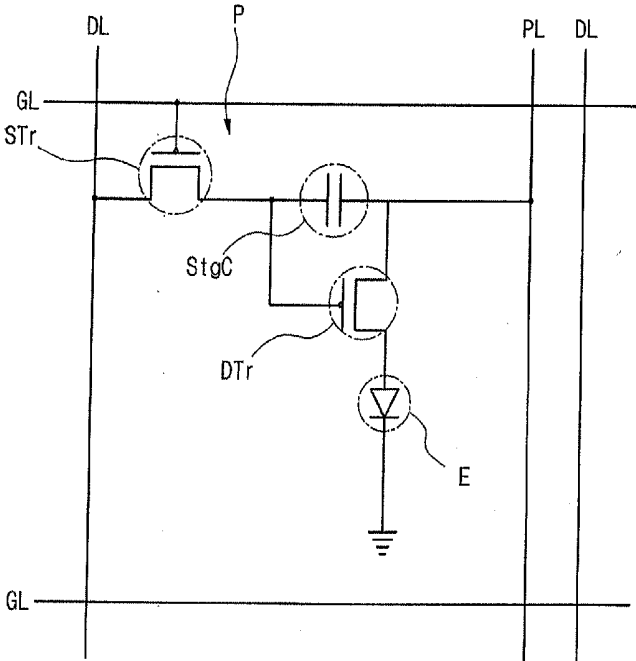

FIG. 3

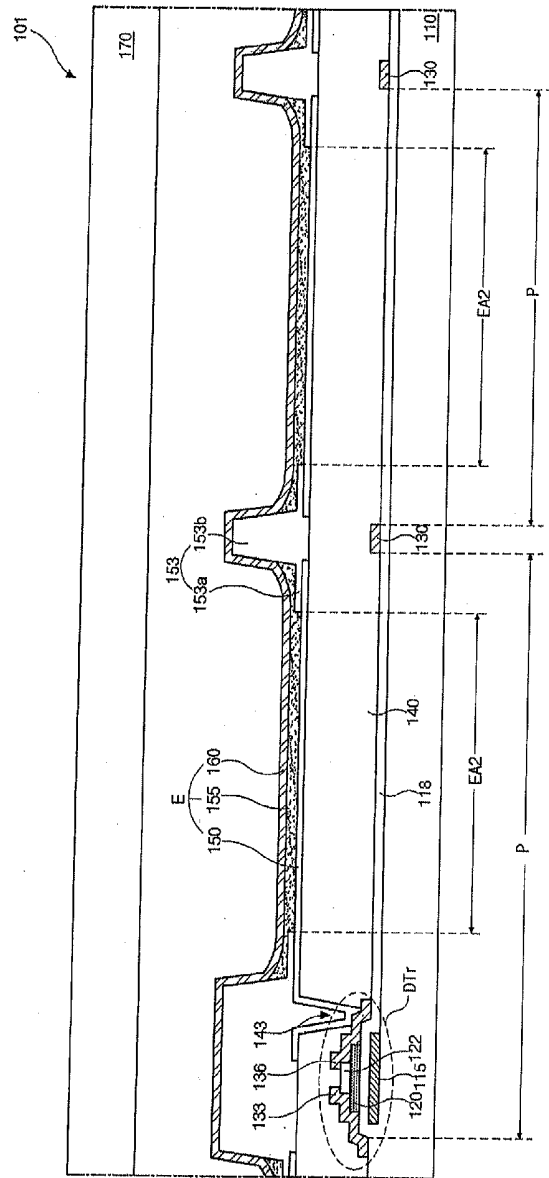

FIG. 4

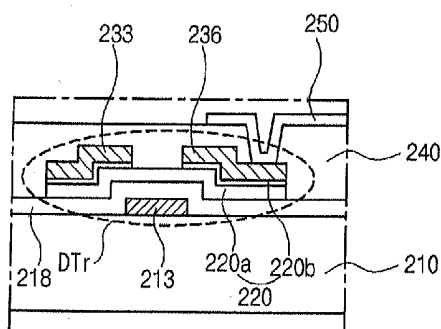

FIG. 5

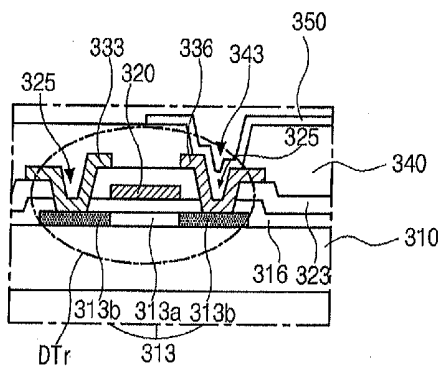

FIG. 6

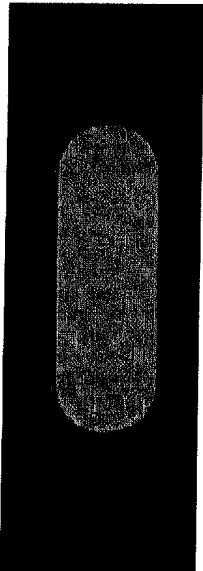

FIG. 7

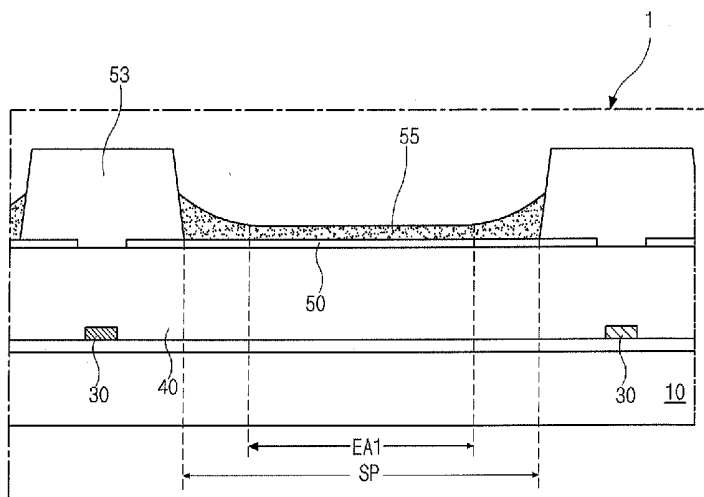

FIG. 8A (Prior Art)

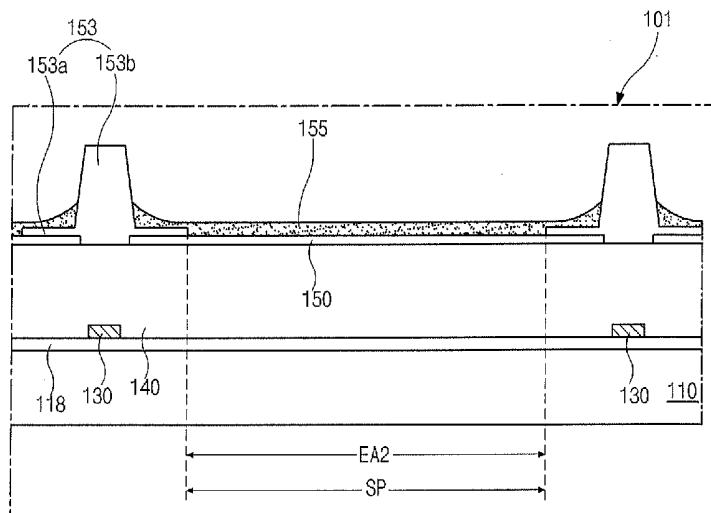

FIG. 8B

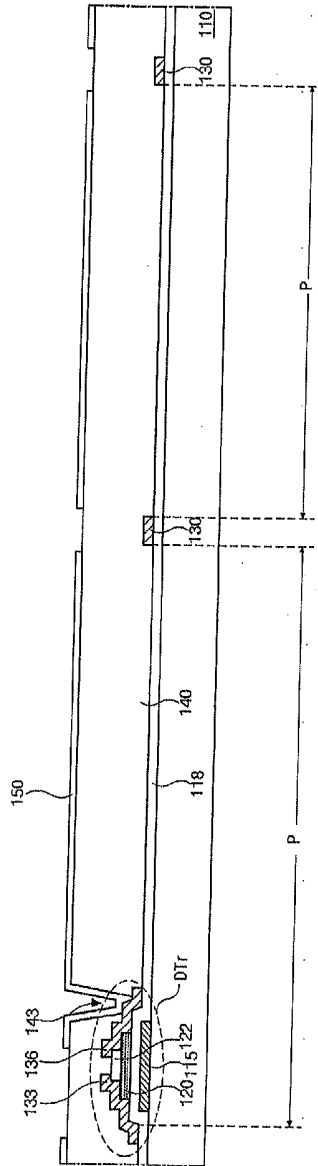

FIG. 9A

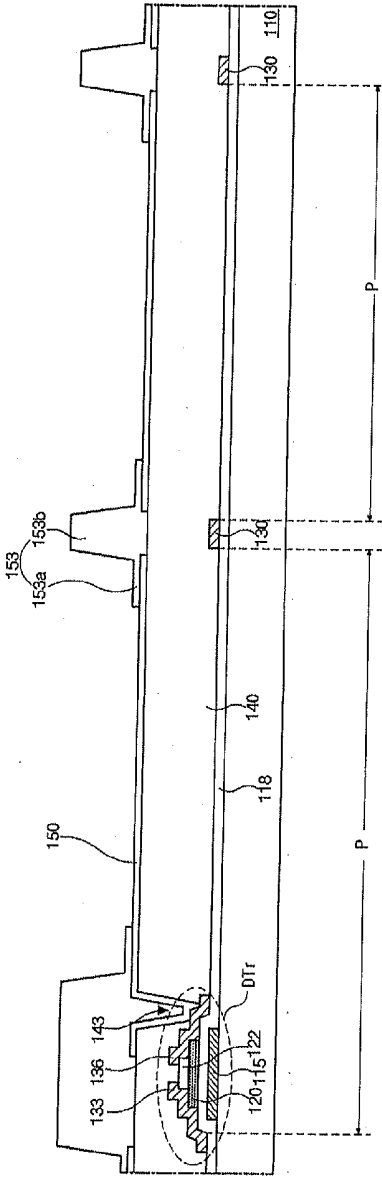

FIG. 9C

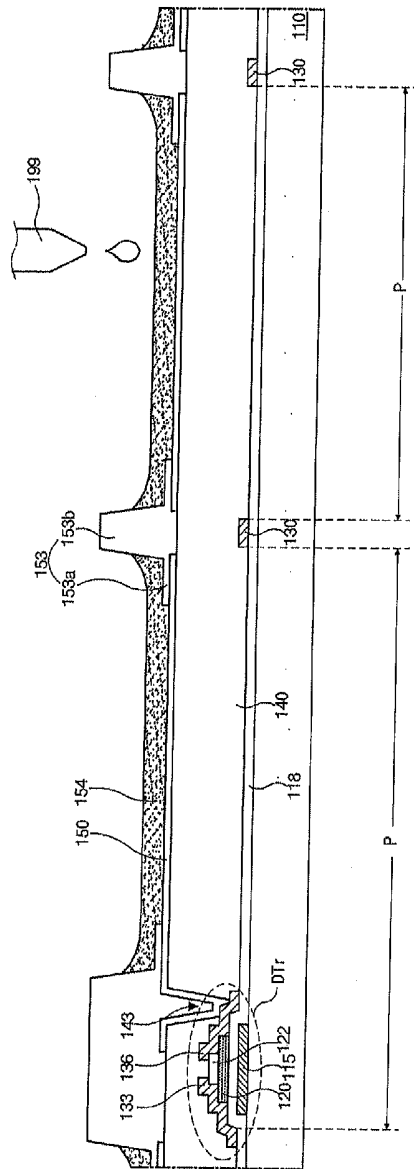

FIG. 9D

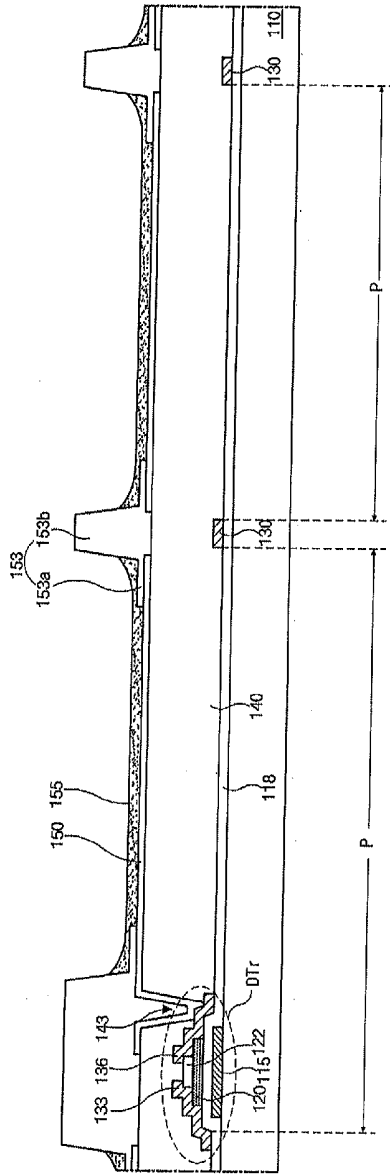

FIG. 9E

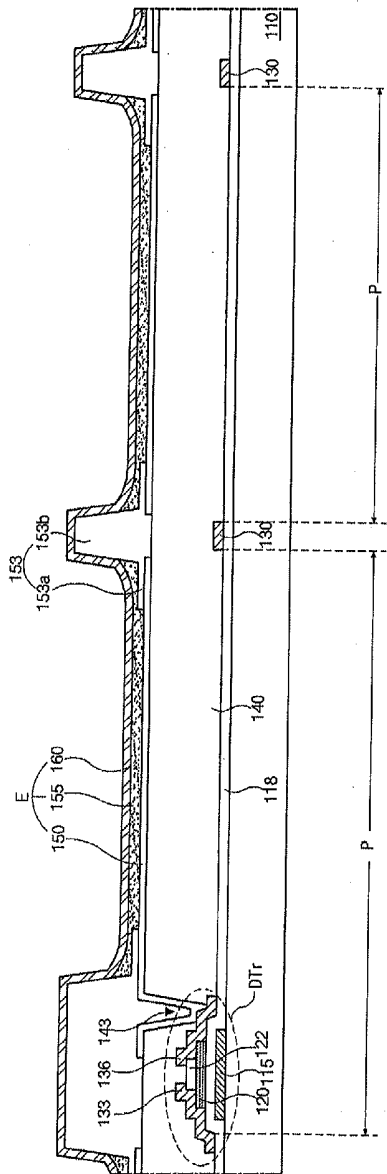

FIG. 9F

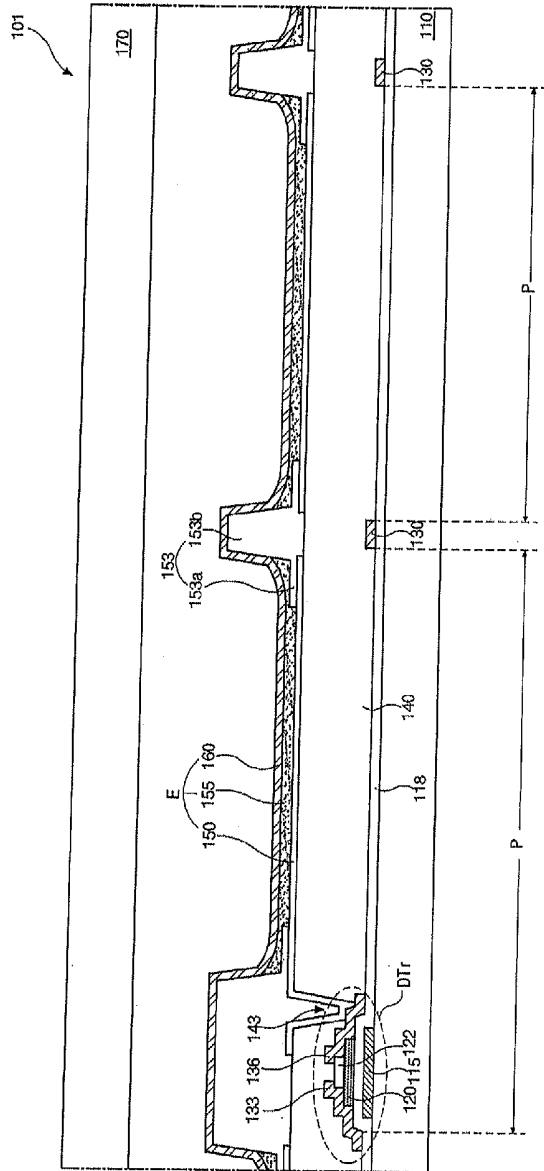

FIG. 9G

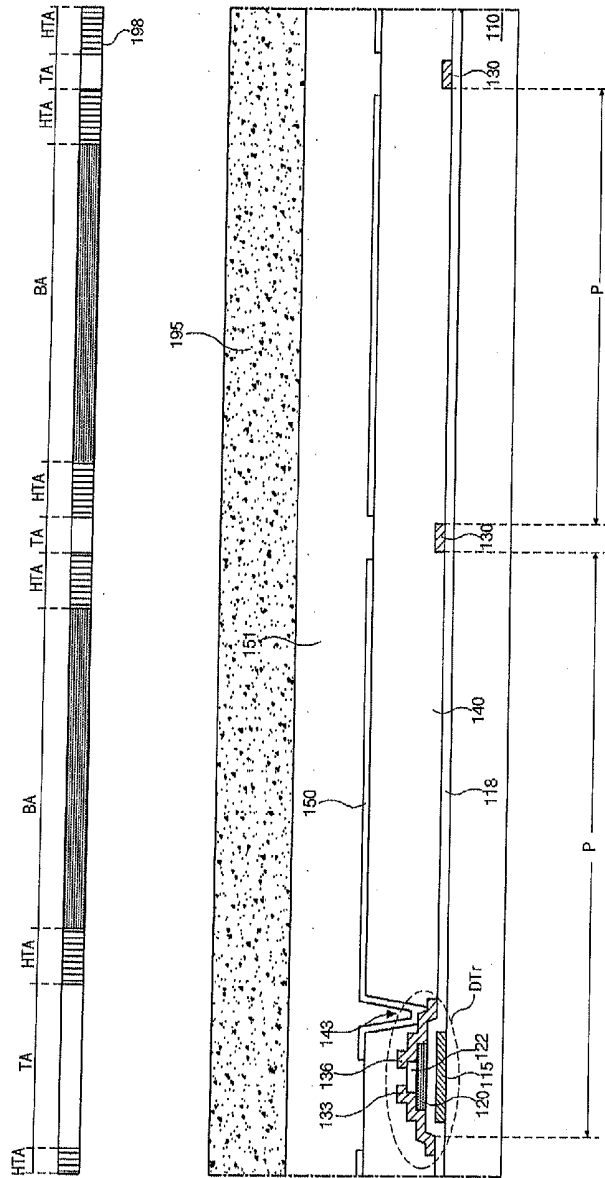

FIG. 10A

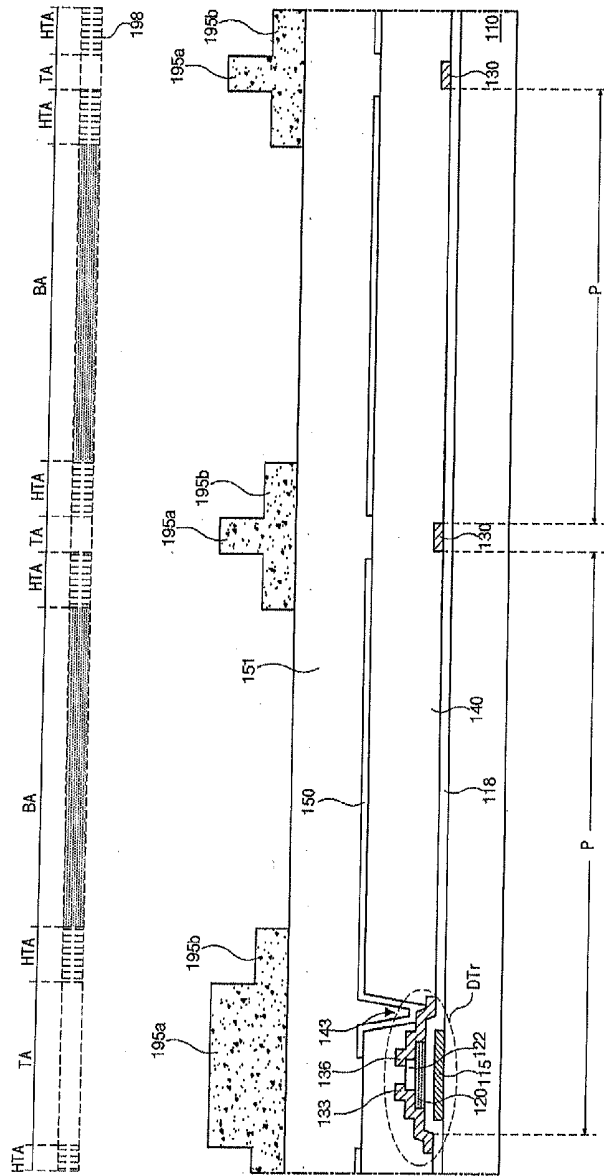

FIG. 10B

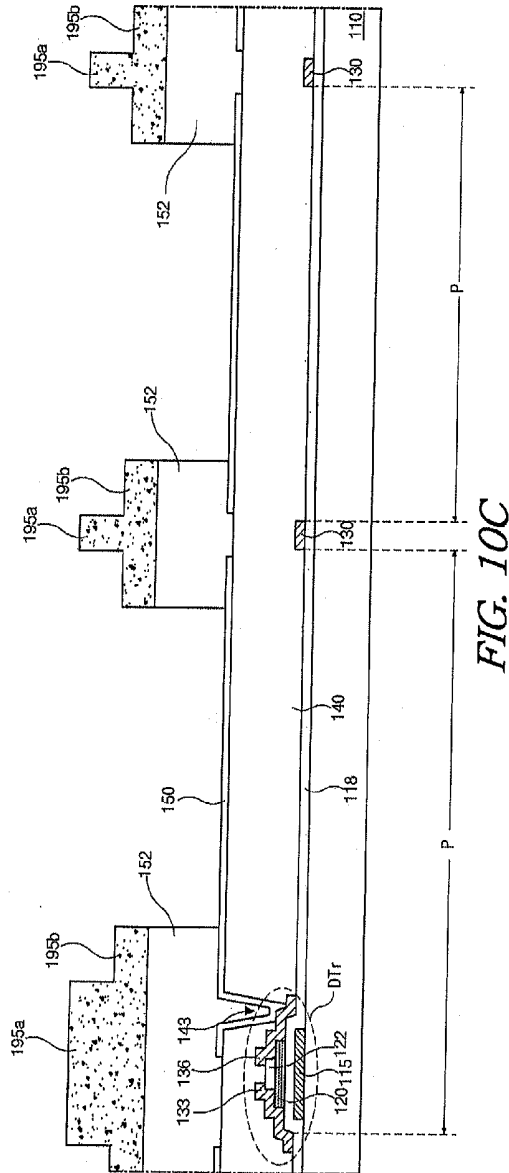

FIG. 10C

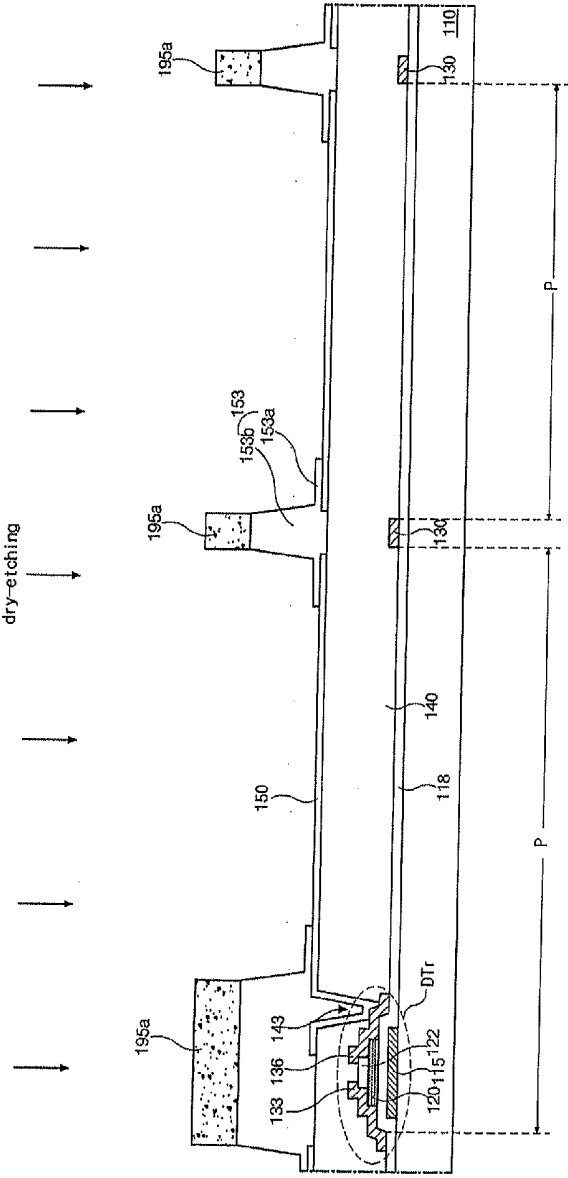

FIG. 10E

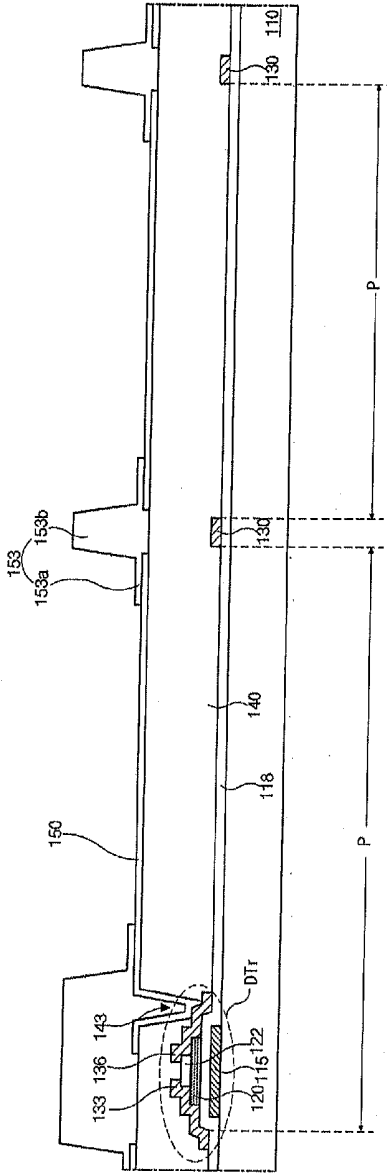

FIG. 10F

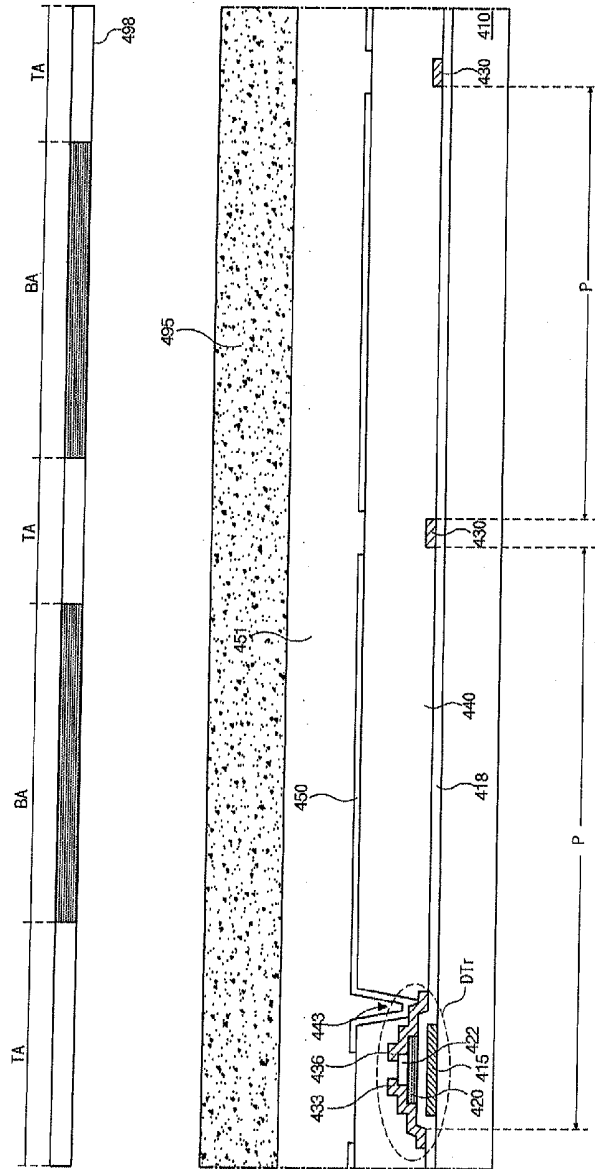

FIG. 11A

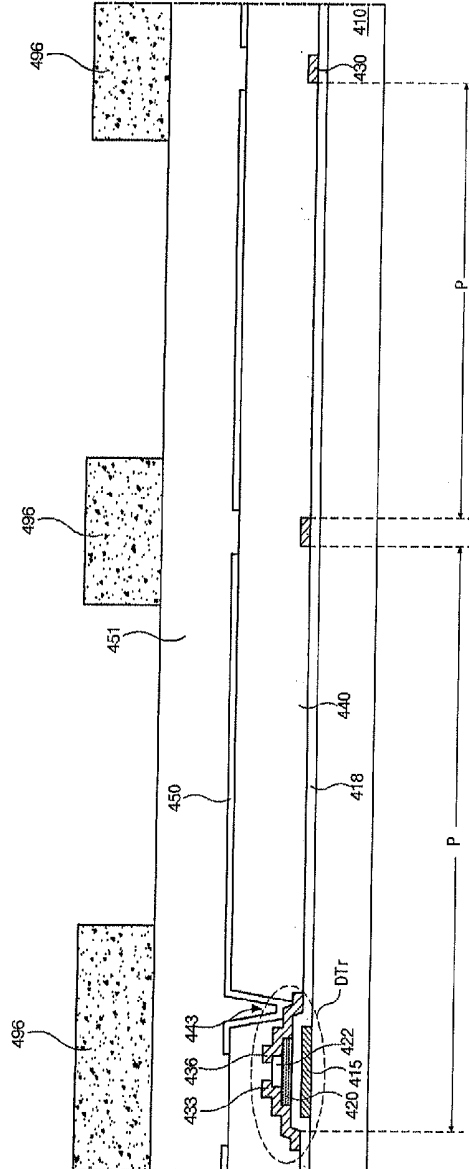

FIG. 11B

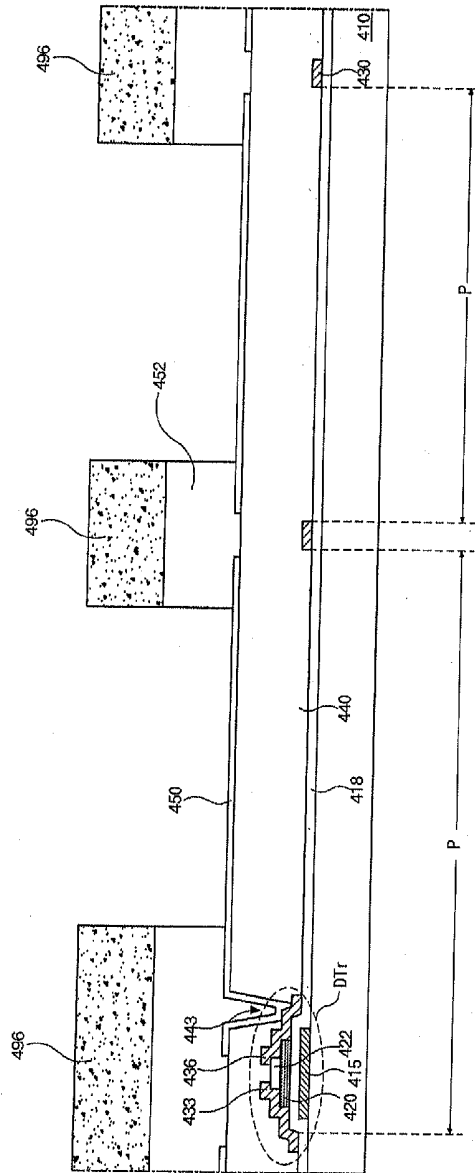

FIG. 11C

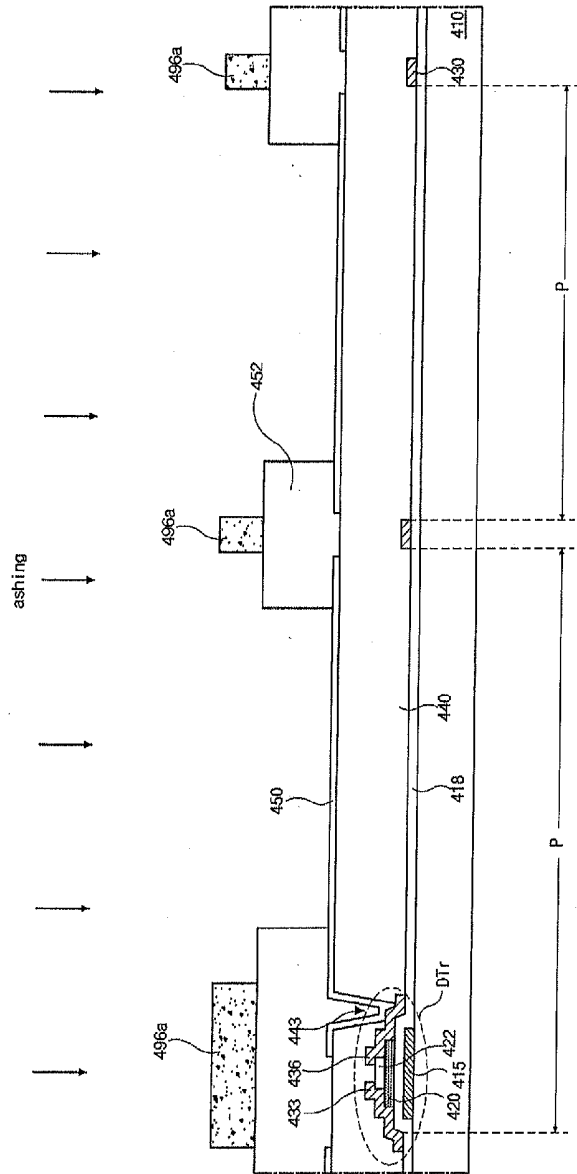

FIG. 11D

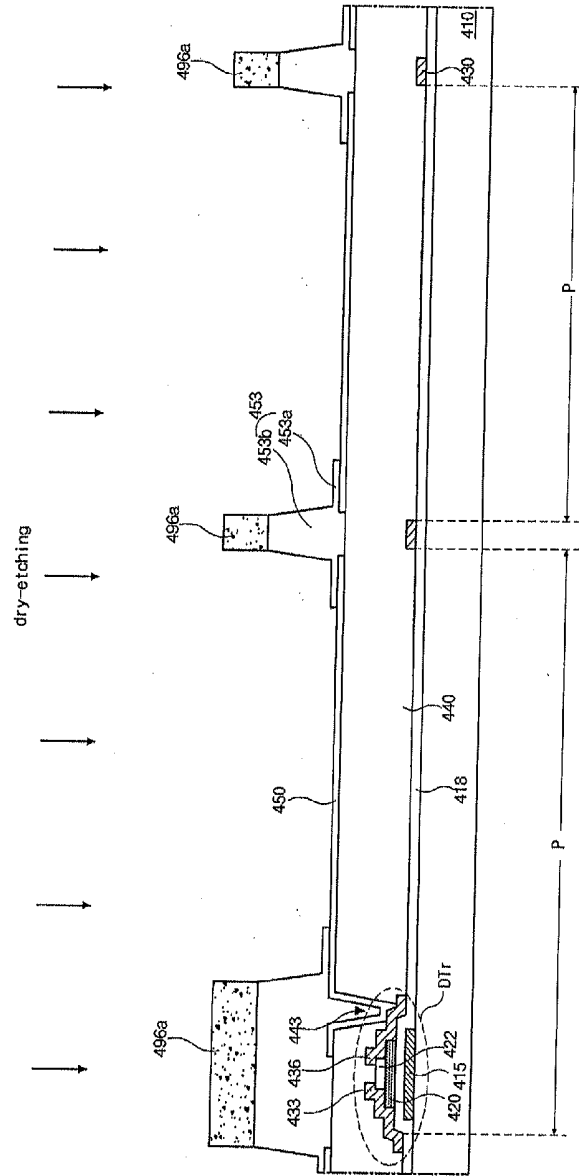

FIG. 11E

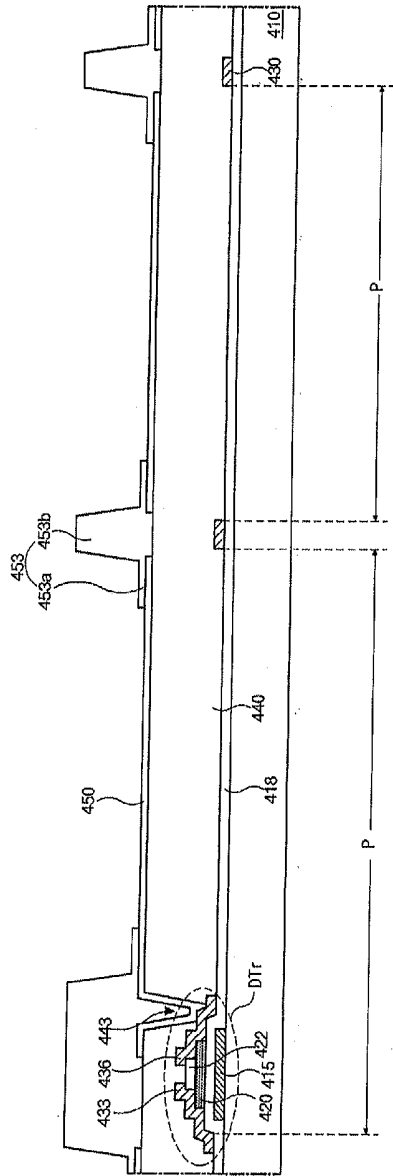

FIG. 11F

**ORGANIC LIGHT EMITTING DIODE
DISPLAY DEVICE AND METHOD OF
FABRICATING THE SAME**

[0001] The present application claims priority to and is a divisional application of U.S. patent application Ser. No. 14/012,321, filed on Aug. 28, 2013, which claims the benefit of Korean Patent Application No. 10-2012-0134299 filed in Korea on Nov. 26, 2012, which is hereby incorporated by reference for all purposes as if fully set forth herein.

BACKGROUND

[0002] 1 Field of the Disclosure

[0003] The disclosure relates to an organic light emitting diode (OLED) display device, which may be referred to as an organic electroluminescent display device, and more particularly, to an OLED display device having improved aperture ratio and lifetime.

[0004] 2. Discussion of the Related Art

[0005] An OLED display device of new flat panel display devices has high brightness and low driving voltage. The OLED display device is a self-emitting type and has excellent view angle characteristics, contrast ratio, a response time, etc.

[0006] Accordingly, the OLED display device is widely used for a television, a monitor, a mobile phone, etc.

[0007] The OLED display device includes an array element and an organic light emitting diode. The array element includes a switching thin film transistor (TFT), which is connected to a gate line and a data line, a driving TFT, which is connected to the switching TFT, and a power line, which is connected to the driving TFT. The organic light emitting diode includes a first electrode, which is connected to the driving TFT, and further includes an organic emitting layer and a second electrode.

[0008] In the OLED display device, light from the organic emitting layer passes through the first electrode or the second electrode to display an image. A top emission type OLED display device, where the light passes through the second electrode, has an advantage in an aperture ratio.

[0009] Generally, the organic emitting layer is formed by a thermal deposition method using a shadow mask. However, the shadow mask sags because the shadow mask becomes larger with an increase in sizes of display devices. As a result, there is a problem in deposition uniformity in the larger display device. In addition, since a shadow effect is generated in the thermal deposition method using the shadow mask, it is very difficult to fabricate a high resolution OLED display device, e.g., above 250 PPI (pixels per inch).

[0010] Accordingly, a new method instead of the thermal deposition method using the shadow mask has been introduced.

[0011] In the new method, a liquid phase organic emitting material is sprayed or dropped in a region surrounded by a wall using an ink-jet apparatus or a nozzle-coating apparatus and cured to form the organic emitting layer.

[0012] FIG. 1 is a schematic cross-sectional view showing an OLED display device in a step of forming an organic emitting layer by spraying or dropping a liquid phase organic emitting material.

[0013] To spray or drop the liquid phase organic emitting material by the ink jet apparatus or the nozzle-coating apparatus, a bank 53, which is formed on the first electrode 50 and surrounds a pixel region P, is required to prevent the liquid phase organic emitting material from flooding into a next

pixel region P. Accordingly, as shown in FIG. 1, the bank 53 is formed on edges of the first electrode 50 before forming the organic emitting layer 55.

[0014] The bank 53 is formed of an organic material having a hydrophobic property. The hydrophobic bank 53 prevents the organic emitting material, which has a hydrophilic property, from being formed on the bank 53 and flooding into a next pixel region P.

[0015] By spraying or dropping the liquid phase organic emitting material from a head of the ink-jet apparatus or a nozzle of the nozzle-coating apparatus into the pixel region P, which is surrounded by the bank 53, the pixel region P is filled with the organic emitting material. The organic emitting material is dried and cured by heat to form the organic emitting layer 55.

[0016] However, the organic emitting layer 55 has a difference in a thickness. Namely, the organic emitting layer 55 has a thickness in edges being larger than a thickness in a center.

[0017] If the organic emitting layer 55 has a thickness difference, the OLED display device has a difference in emitting efficiency. Accordingly, as shown in FIG. 2, which is a picture showing one pixel region in the related art OLED display device, dark images are displayed in edges of the pixel region. In this instance, since the dark images are perceived as an image defect by the viewer, the edges of the pixel region should be shielded such that the edges of the pixel region do not serve as an effective emission area.

[0018] Referring again to FIG. 1, an effective emission area EA1 is a portion of the pixel region P where the organic emitting layer 55 has a flat top surface. Namely, the aperture ratio of the OLED display device is decreased.

SUMMARY

[0019] A method of fabricating an organic light emitting diode display device includes forming a first electrode over a substrate including a display region, which includes a plurality of pixel regions, the first electrode formed in each of the plurality of pixel regions; forming a bank including a lower layer and an upper layer, the lower layer formed on edges of the first electrode and having a first width and a first thickness, and the upper layer formed on the lower layer and having a second width smaller than the first width; forming an organic emitting layer on the first electrode and a portion of the lower layer; and forming a second electrode on the organic emitting layer, the second electrode covering an entire surface of the display region.

[0020] In another aspect, an organic light emitting diode display device includes a substrate including a display region, wherein a plurality of pixel regions are defined in the display region; a first electrode over the substrate and in each of the plurality of pixel regions; a bank including a lower layer and an upper layer on the first electrode, the lower layer disposed on edges of the first electrode and having a first width and a first thickness, the upper layer disposed on the lower layer and having a second width smaller than the first width; an organic emitting layer on the first electrode and a portion of the lower layer; and a second electrode on the organic emitting layer and covering an entire surface of the display region.

[0021] It is to be understood that both the foregoing general description and the following detailed description are exemplary and explanatory and are intended to provide further explanation of the invention as claimed.

BRIEF DESCRIPTION OF THE DRAWINGS

[0022] The accompanying drawings, which are included to provide a further understanding of the invention and are incorporated in and constitute a part of this specification, illustrate embodiments of the invention and together with the description serve to explain the principles of the invention.

[0023] FIG. 1 is a schematic cross-sectional view showing an OLED display device in a step of forming an organic emitting layer by spraying or dropping a liquid phase organic emitting material.

[0024] FIG. 2 is a picture showing one pixel region in the related art OLED display device.

[0025] FIG. 3 is a circuit diagram of one pixel region of an OEM device.

[0026] FIG. 4 is a schematic cross-sectional view of an OLED display device according to an embodiment of the present invention.

[0027] FIG. 5 is a schematic cross-sectional view of an OLED display device according to one modified embodiment of the present invention.

[0028] FIG. 6 is a schematic cross-sectional view of an OLED display device according to another modified embodiment of the present invention.

[0029] FIG. 7 is a picture showing one pixel region in an OLED display device according to the present invention.

[0030] FIGS. 8A and 8B are schematic cross-sectional views explaining effective emission areas of the prior art OLED display device (see FIG. 8A) and an OLED display device according to the present invention (see FIG. 8B).

[0031] FIGS. 9A to 9G are cross-sectional views showing a fabricating process of an OLED display device according to a first embodiment of the present invention.

[0032] FIGS. 10A to 10F are cross-sectional views showing a fabricating process of an OLED display device according to another example of the first embodiment of the present invention.

[0033] FIGS. 11A to 11F are cross-sectional views showing a fabricating process of an OLED display device according to a second embodiment of the present invention.

DETAILED DESCRIPTION

[0034] Reference will now be made in detail to the preferred embodiments, examples of which are illustrated in the accompanying drawings.

[0035] FIG. 3 is a circuit diagram of one pixel region of an OLED device.

[0036] As shown in FIG. 3, an OLED display device includes a switching thin film transistor (TFT) STr, a driving TFT DTr, a storage capacitor StgC and an emitting diode E in each pixel region P.

[0037] On a substrate (not shown), a gate line GL along a first direction and a data line DL along a second direction are formed. The gate line GL and the data line DL cross each other to define the pixel region P. A power line PL for providing a source voltage to the emitting diode E is formed to be parallel to and spaced apart from the data line DL.

[0038] The switching TFT STr is connected to the gate and data lines GL and DL, and the driving TFT DTr and the storage capacitor StgC are connected to the switching TFT STr and the power line PL. The emitting diode E is connected to the driving TFT DTr.

[0039] A first electrode of the emitting diode E is connected to a drain electrode of the driving TFT DTr, and a second electrode of the emitting diode E is grounded.

[0040] When the switching TFT STr is turned on by a gate signal applied through the gate line GL, a data signal from the data line DL is applied to the gate electrode of the driving TFT DTr and an electrode of the storage capacitor StgC. When the driving TFT DTr is turned on by the data signal, an electric current is supplied to the emitting diode E from the power line PL. As a result, the emitting diode E emits light. In this case, when the driving TFT DTr is turned on, a level of an electric current applied from the power line PL to the emitting diode E is determined such that the emitting diode E can produce a gray scale. The storage capacitor StgC serves to maintain the voltage of the gate electrode of the driving TFT DTr when the switching TFT STr is turned off. Accordingly, even if the switching TFT STr is turned off, a level of an electric current applied from the power line PL to the emitting diode E is maintained to a next frame.

[0041] FIG. 4 is a schematic cross-sectional view of an OLED display device according to an embodiment of the present invention. FIG. 4 shows one driving TFT DTr in one pixel region P. However, the driving TFT DTr is formed in each pixel region P.

[0042] As shown in FIG. 4, an OLED display device 101 of the present invention includes a first substrate 110, where a driving TFT DTr, a switching TFT (not shown) and an organic emitting diode E are formed, and a second substrate 170 for encapsulation. The second substrate 170 may be an inorganic insulating film or an organic insulating film.

[0043] A gate line (not shown) and a data line 130 are formed on the first substrate 110. The gate line and the data line 130 cross each other to define the pixel region P. A power line (not shown) for providing a voltage to the emitting diode E is formed to be parallel to and spaced apart from the data line 130.

[0044] In each pixel region P, the switching TFT is connected to the gate line and the data line 130, and the driving TFT DTr and the storage capacitor StgC are connected to the switching TFT and the power line.

[0045] The driving TFT DTr includes a gate electrode 115, a gate insulating layer 118, an oxide semiconductor layer 120, an etch-stopper 122, a source electrode 133 and a drain electrode 136. The gate insulating layer 118 covers the gate electrode 115, and the oxide semiconductor layer 120 is disposed on the gate insulating layer 118. The oxide semiconductor layer 120 corresponds to the gate electrode 115. The etch-stopper 122 covers a center of the oxide semiconductor layer 120. The source electrode 133 and the drain electrode 136 are disposed on the etch-stopper 122 and spaced apart from each other. The source electrode 133 and the drain electrode 136 contact both ends of the oxide semiconductor layer 120, respectively. Although not shown, the switching TFT has substantially the same structure as the driving TFT DTr.

[0046] In FIG. 4, each of the driving TFT DTr and the switching TFT includes the oxide semiconductor layer 120 of an oxide semiconductor material. Alternatively, as shown in FIG. 5, each of the driving TFT DTr and the switching TFT may include a gate electrode 213, a gate insulating layer 218, a semiconductor layer 220 including an active layer 220a of intrinsic amorphous silicon and an ohmic contact layer 220b of impurity-doped amorphous silicon, a source electrode 233 and a drain electrode 236.

[0047] Meanwhile, each of the driving TFT DTr and the switching TFT may have a top gate structure where the semiconductor layer is positioned at a lowest layer. Namely, as shown in FIG. 6, each of the driving TFT DTr and the switching TFT may include a semiconductor layer 313, which includes an active region 313a of intrinsic poly-silicon and impurity-doped regions 313b at both sides of the active region 313a, on a first substrate 310, a gate insulating layer 316, a gate electrode 320 corresponding to the active region 313a of the semiconductor layer 313, an interlayer insulating layer 323 having semiconductor contact holes 325, which expose the impurity-doped regions 313b of the semiconductor layer 313, and source and drain electrodes 333 and 336 respectively connected to the impurity-doped regions 313b through the semiconductor contact holes 325.

[0048] The top gate structure TFT requires the interlayer insulating layer 323 in comparison to a bottom gate structure TFT. In the top gate structure TFT, the gate line (not shown) is formed on the gate insulating layer 316, and the data line (not shown) is formed on the interlayer insulating layer 323.

[0049] Referring again to FIG. 4, a passivation layer 140, which includes a drain contact hole 143 exposing the drain electrode 136 of the driving TFT DTr, is formed over the driving TFT DTr and the switching TFT. For example, the passivation layer 140 may be formed of an organic insulating material, e.g., photo-acryl, to have a flat top surface.

[0050] A first electrode 150, which contacts the drain electrode 136 of the driving TFT DTr through the drain contact hole 143, is formed on the passivation layer 140 and separately in each pixel region P.

[0051] The first electrode 150 is formed of a conductive material having a relatively high work function, e.g., about 4.8 eV to 5.2 eV. For example, the first electrode 150 may be formed of a transparent conductive material such as indium-tin-oxide (ITO) to serve as an anode.

[0052] When the first electrode 150 is formed of the transparent conductive material, a reflection layer (not shown) may be formed under the first electrode 150 to increase emission efficiency in a top emission type OLED display device. For example, the reflection layer may be formed of a metallic material, such as aluminum (Al) or Al alloy such as AlNd, having a relatively high reflectivity.

[0053] With the reflection layer, the light from an organic emitting layer 155, which is formed on the first electrode 150, is reflected by the reflection layer such that the emission efficiency is increased. As a result, the OLED display device has an improved brightness property.

[0054] A bank 153 having a double-layered structure, which includes a lower layer 153a and an upper layer 153b, is formed along boundaries of the pixel region P. The lower layer 153a has a first width, and the upper layer 153b has a second width narrower than the first width. The lower layer 153a of the bank 153 is formed on edges of the first electrode 150 such that a center of the first electrode 150 is exposed by the lower layer 153a, and the upper layer 153b is disposed on the lower layer 153a. The bank 153 includes a hydrophobic material. For example, the bank 153 may be formed of an organic insulating material having a hydrophobic property or an organic insulating material containing a hydrophobic material.

[0055] At this time, a thickness of the lower layer 153a is thinner than a thickness of the organic emitting layer 155, which is formed on the lower layer 153a. The thickness of the lower layer 153a may be within a range of 0.2 micrometers to

1.5 micrometers. Additionally, the lower layer 153a is exposed outwards side surfaces of the upper layer 153b, and an exposed width of the lower layer 153a may be within a range of 1 micrometer to 9 micrometers.

[0056] The first width of the lower layer 153a is substantially the same as that of the bank 53 having a single-layered structure in the related art OLED display device of FIG. 1.

[0057] In the OLED display device 101 including the bank 153a of a double-layered structure, which includes the lower layer 153a having the first width and the thickness smaller than the organic emitting layer 155 and the upper layer 153b having the second width smaller than the first width, the organic emitting layer 155 is formed on the lower layer 153a of the bank 153 exposed outwards the side surfaces of the upper layer 153b, and the organic emitting material flows into a center of the pixel region P due to the lower layer 153a of the bank 153. As a result, a problem of an increase in the thickness of the organic emitting layer 155 is reduced in a region adjacent to the bank 153.

[0058] In addition, since the lower layer 153a of the bank 153 has substantially the same width as the bank 53 of FIG. 1 of the related art, a region surrounded by the upper layer 153b of the bank 153, which has the second width smaller than the first width of the lower layer 153a of the bank 153, is larger than that surrounded by the bank 53 of the related art when the pixel region has the same size in the present invention and the related art.

[0059] Moreover, since the lower layer 153a of the bank 153 has the thickness smaller than the organic emitting layer 155, the organic emitting layer 155 is formed on the lower layer 153a of the bank 153.

[0060] Furthermore, since the organic emitting layer 155 on the lower layer 153a of the bank 153 has a portion forming a substantially flat top surface with the center of the pixel region P, the flat top surface of the organic emitting layer 155 is increased in the pixel region P, and the organic emitting layer 155 has the flat top surface in a region surrounded by the lower layer 153a of the bank 153.

[0061] Accordingly, an emission area EA2, which is defined as a region of the organic emitting layer 155 having the flat top surface, is increased in comparison to the emission area EA1 of FIG. 1 in the related art OLED display device such that the OLED display device of the present invention has an improved aperture ratio.

[0062] FIG. 7 is a picture showing one pixel region in an OLED display device according to the present invention when the OLED display device is driven. Here, the OLED display device includes a bank, which has a double-layered structure including two layers of different widths, and an organic emitting layer, which is formed on the bank and formed of a liquid phase organic emitting material.

[0063] Referring to FIG. 7, the emission area EA2 of FIG. 4 in the OLED display device of the present invention is increased in comparison to the emission area EA1 of FIG. 1 in the related art OLED display device. In addition, uniformity in brightness of the OLED display device of the present invention is improved due to the organic emitting layer 155 of FIG. 4 having the flat top surface all over the emission area EA2 of FIG. 4.

[0064] FIGS. 8A and 8B are schematic cross-sectional views explaining effective emission areas of the prior art OLED display device (see FIG. 8A) and an OLED display device according to the present invention (see FIG. 8B).

[0065] As shown in FIGS. 8A and 8B, with the pixel region of the same size defined by the gate line (not shown) and the data line 30 or 130, an effective pixel region SP is defined as a region surrounded by the bank 53 or 153. In this instance, referring to FIG. 8A, the effective pixel region SP in the prior art OLED display device is a region surrounded by the bank 53, while the effective pixel region SP in the OLED display device of the present invention is a region surrounded by the lower layer 153a of the bank 153 having the first width. The areas of the effective pixel regions SP in the prior art OLED display device and the OLED display device of the present invention are equal to each other.

[0066] However, a size of the effective emission area EA2 in the effective pixel region SP of the OLED display device of the present invention is larger than that of the effective emission area EA1 in the effective pixel region SP of the prior art OLED display device.

[0067] Since the organic emitting layer 55 of the prior art OLED display device has different thicknesses in the center and the edge of the effective pixel region SP, the effective emission area EA1 is smaller than the effective pixel region SP. However, since the organic emitting layer 155 of the OLED display device 101 according to the present invention has a uniform thickness in an entire surface of the effective pixel region SP, the effective emission area EA2 is equal to the effective pixel region SP. Namely, a size of the effective emission area EA2 in the effective pixel region SP of the OLED display device of the present invention is larger than that of the effective emission area EA1 in the effective pixel region SP of the prior art OLED display device such that the aperture ratio of the OLED display device is increased.

[0068] Referring again to FIG. 4, the organic emitting layer 155 is formed on the first electrode 150 and on the lower layer 153a of the bank 153 in an opening of the upper layer 153b of the bank 153. The organic emitting layer 155 includes red, green and blue emitting materials in respective pixel regions P.

[0069] The organic emitting layer 155 is formed by forming an organic emitting material layer and curing the organic emitting material layer. The organic emitting material layer is formed by coating, i.e., spraying or dropping a liquid phase organic emitting material by an ink-jet apparatus or a nozzle-coating apparatus.

[0070] FIG. 4 shows a single-layered organic emitting layer 155. Alternatively, to improve emission efficiency, the organic emitting layer 155 may have a multi-layered structure. For example, the organic emitting layer 155 may include a hole injecting layer, a hole transporting layer, an emitting material layer, an electron transporting layer and an electron injecting layer stacked on the first electrode 150 as an anode. The organic emitting layer 155 may be a quadruple-layered structure of the hole transporting layer, the emitting material layer, the electron transporting layer and an electron injecting layer or a triple-layered structure of the hole transporting layer, the emitting material layer and the electron transporting layer.

[0071] A second electrode 160 is formed on the organic emitting layer 155 and covers an entire surface of a display region of the first substrate 110. The second electrode 160 is formed of a metallic material having a relatively low work function, e.g., Al, Al alloy, silver (Ag), magnesium (Mg), gold (Au), or Al—Mg alloy (AlMg). The second electrode 160 serves as a cathode.

[0072] The first electrode 150, the organic emitting layer 155 and the second electrode 160 constitute the emitting diode E.

[0073] A seal pattern (not shown) of a sealant or a frit material is formed on edges of the first substrate 110 or the second substrate 170. The first and second substrates 110 and 170 are attached using the seal pattern. A space between the first and second substrates 110 and 170 has a vacuum condition or an inert gas condition. The second substrate 170 may be a flexible plastic substrate or a glass substrate.

[0074] Alternatively, the second substrate 170 may be a film contacting the second electrode 160. In this instance, the film-type second substrate is attached to the second electrode 160 by an adhesive layer.

[0075] In addition, an organic insulating film or an inorganic insulating film may be formed on the second electrode 160 as a capping layer. In this instance, the organic insulating film or the inorganic insulating film serves as the encapsulation film without the second substrate 170.

[0076] In the OLED display device 101 including the lower layer 153a of the bank 153, which has the thickness being smaller than the organic emitting layer 155 and has a hydrophobic property, and the upper layer 153b of the bank 153, which has the second width smaller than the first width of the lower layer 153a, the organic emitting layer 155 is formed on the lower layer 153a and the organic emitting material is concentrated into a center of the pixel region P by the lower layer 153a. As a result, a problem of an increase in the thickness of the organic emitting layer 155 is reduced in a region adjacent to the lower layer 153a.

[0077] In addition, since the organic emitting layer 155 on the lower layer 153a of the bank 153 has a portion forming a substantially flat top surface with the center of the pixel region P, the organic emitting layer 155 has a uniform thickness in a region surrounded by the lower layer 153a of the bank. As a result, an emission area EA2 is increased in comparison to the emission area EA1 of FIG. 1 in the prior art OLED display device such that the OLED display device of the present invention has the improved aperture ratio.

[0078] Moreover, since an area having thickness uniformity of the organic emitting layer 155 is increased, brightness uniformity of the OLED display device of the present invention is improved. Furthermore, due to the thickness uniformity of the organic emitting layer 155, a thermal degradation problem of the organic emitting layer is prevented such that the OLED display device has an improved lifetime.

[0079] Hereinafter, a method of fabricating the OLED display device is explained with reference to FIGS. 9A to 9G. FIGS. 9A to 9G are cross-sectional views showing a fabricating process of an OLED display device according to a first embodiment of the present invention. The explanation is focused on a bank having a double-layered structure with different widths.

[0080] As shown in FIG. 9A, on the first substrate 110, the gate line (not shown), the data line (not shown) and the power line (not shown) are formed. In addition, the switching TFT (not shown) connected to the gate and data lines and the driving TFT DTr connected to the switching TFT and the power line are formed.

[0081] As explained above, each of the switching TFT and the driving TFT DTr has a bottom gate type TFT including the gate electrode 115 of FIG. 4 or 213 of FIG. 5 as a lowest layer or a top gate type TFT including the semiconductor layer 313 of FIG. 6 as a lowest layer. The bottom gate type TFT includes

the oxide semiconductor layer **120** of FIG. **4** or the amorphous silicon semiconductor layer **220** of FIG. **5** including the active layer **220a** and the ohmic contact layer **220b**, and the top gate type TFT includes the poly-silicon semiconductor layer **313** of FIG. **6**.

[0082] Here, the switching TFT and the driving TFT DTr may be the bottom gate type TFT including an oxide semiconductor layer. Therefore, the gate electrode **115** of the driving TFT DTr is formed on the first substrate **110**, the gate insulating layer **118** is formed on the gate electrode **115**, and the oxide semiconductor layer **120** is formed on the gate insulating layer **118** corresponding to the gate electrode **115**. The etch-stopper **122** is formed on the oxide semiconductor layer **120** and covers the center of the oxide semiconductor layer **120**. The source and drain electrodes **133** and **136** are formed on the etch-stopper **122** and spaced apart from each other.

[0083] Next, an organic insulating material, e.g., photoacryl, is coated over the switching TFT and the driving TFT DTr and is patterned to form the passivation layer **140** having a flat top surface and including the drain contact hole **143**. The drain electrode **136** of the driving TFT DTr is exposed through the drain contact hole **143**.

[0084] Next, a transparent conductive material, which has a relatively high work function, is deposited on the passivation layer **140** and patterned to form the first electrode **150**. The first electrode **150** contacts the drain electrode **136** of the driving TFT DTr through the drain contact hole **143** and is separated in each pixel region P. For example, the transparent conductive material may be indium tin oxide (ITO).

[0085] Meanwhile, as explained above, the reflection layer (not shown), which includes Al or Al alloy, may be formed under the first electrode **150** and on the passivation layer **140**. The reflection layer may be formed by the same mask process as the first electrode **150**.

[0086] Next, as shown in FIG. **9B**, a bank material layer **151** is formed on the first electrode **150** and the passivation layer **140**. For example, the bank material layer **151** may be formed by coating a polymer material having a hydrophobic property. The polymer material may include at least one of polyimide containing fluorine (F), styrene, methylmethacrylate, and polytetrafluoroethylene. At this time, the polymer material may include a photosensitive material having a photosensitive property.

[0087] An exposing mask **198** including a transmitting region TA, a blocking region BA and a half-transmitting region HTA is disposed over the bank material layer **151**, and an exposing process to the bank material layer **151** is performed using the exposing mask **198** without an additional photoresist layer.

[0088] Here, the bank material layer **151** is shown to have a negative type photosensitive property where an exposed portion of the bank material layer **151** remains after a developing process. Alternatively, the bank material layer **151** may have a positive type photosensitive property, and at this time, a position of the transmitting region TA and the blocking region BA is switched.

[0089] Next, as shown in FIG. **9C**, the bank **153** including the lower layer **153a** and the upper layer **153b** is formed by developing the bank material layer **151** of FIG. **9B** exposed to light. In this instance, an exposed portion of the bank material layer **151** of FIG. **9B** corresponding to the transmitting region TA of the exposing mask **198** remains to form the upper layer **153b** having the same thickness as the bank material layer **151**

of FIG. **9B**, a non-exposed portion of the bank material layer **151** corresponding to the blocking region BA of the exposing mask **198** is removed by the developing process, and a partially-exposed portion of the bank material layer **151** of FIG. **9B** is partially removed to form the lower layer **153a** having the thickness smaller than that of the upper layer **153b**.

[0090] Accordingly, after the developing process, the bank **153** having the double-layered structure is formed in the edge of each pixel region P such that the upper layer **153b** having the second width is disposed in a center of the edge of each pixel region P and the lower layer **153a** having the first width larger than the second width is exposed outwards the side surfaces of the upper layer **153b**. The exposed width of the lower layer **153a** may be 1 micrometer to 9 micrometers, and the thickness of the lower layer **153a** may be 0.2 micrometers to 1.5 micrometers.

[0091] Meanwhile, the bank material layer **151** of FIG. **9B** may include a hydrophobic polymer material without a photosensitive property. This will be explained as another example of the first embodiment with reference to FIGS. **10A** to **10F**. FIGS. **10A** to **10F** are cross-sectional views showing a fabricating process of an OLED display device according to another example of the first embodiment of the present invention.

[0092] As shown in FIG. **10A**, a bank material layer **151** is formed on the first electrode **150** all over the first substrate **110**. The bank material layer **151** may be formed by coating a polymer material having a hydrophobic property without a photosensitive property.

[0093] Next, a photoresist layer **195** is formed on the bank material layer **151** by applying photoresist.

[0094] Then, an exposing mask **198** including a transmitting region TA, a blocking region BA and a half-transmitting region HTA is disposed over the photoresist layer **195**, and an exposing process to the photoresist layer **195** is performed using the exposing mask **198**.

[0095] Here, the photoresist layer **195** is shown to have a negative type photosensitive property where an exposed portion of the photoresist layer **195** remains after a developing process. The exposing mask **198** is disposed such that the transmitting region TA and the half-transmitting region HTA correspond to the edge of each pixel region P, and the blocking region BA corresponds to the center of the pixel region P.

[0096] Next, as shown in FIG. **10B**, a first photoresist pattern **195a** and a second photoresist pattern **195b** are formed by developing the photoresist layer **195** of FIG. **10A** exposed to light through the exposing mask **198**. In this instance, an exposed portion of the photoresist layer **195** of FIG. **10A** corresponding to the transmitting region TA of the exposing mask **198** remains to form the first photoresist pattern **195a** having a first thickness the same as the photoresist layer **195** of FIG. **10A**, a non-exposed portion of the photoresist layer **195** of FIG. **10A** corresponding to the blocking region BA of the exposing mask **198** is removed by the developing process, and a partially-exposed portion of the photoresist layer **195** of FIG. **10A** is partially removed to form the second photoresist pattern **195b** having a second thickness smaller than the first thickness.

[0097] In FIG. **10C**, a bank pattern **152** is formed under the first and second photoresist patterns **195a** and **195b** by removing the bank material layer **151** of FIG. **10B** exposed by the first and second photoresist patterns **195a** and **195b** through an etching process. The bank pattern **152** is disposed in the edge of the pixel region P and has a uniform thickness.

[0098] Next, in FIG. 10D, the second photoresist pattern **195b** of FIG. 10C having the second thickness is removed by performing an etching process, and the bank pattern **152** is partially exposed outwards side surfaces of the first photoresist pattern **195a**. Here, the first photoresist pattern **195a** is also partially removed, so that the thickness of the first photoresist pattern **195a** is reduced.

[0099] In FIG. 10E, the bank pattern **152** of FIG. 10D exposed by the first photoresist pattern **195a** is dry-etched and partially removed to thereby form the lower layer **153a** of the bank **153** such that the lower layer **153a** of the bank **153** has a thickness of 0.2 micrometers to 1.5 micrometers. At the same time, a portion of the bank pattern **152** of FIG. 10D, which is disposed under the first photoresist pattern **195a** and is not dry-etched, becomes the upper layer **153b** of the bank **153**.

[0100] Here, the width of the lower layer **153a** of the bank **153** exposed outwards the side surfaces of the upper layer **153b** of the bank **153** may be 1 micrometer to 9 micrometers.

[0101] Next, as shown in FIG. 10F, the first photoresist pattern **195a** of FIG. 10E is removed by performing a stripping process, thereby completing the bank **153** of the double-layered structure having the different widths in another example of the first embodiment.

[0102] In the meantime, as shown in FIG. 9D, after forming the bank **153** having the double-layered structure, an organic emitting material layer **154** is formed on the first electrode **150** and the lower layer **153a** of the bank **153** by spraying or dropping a liquid phase organic emitting material in a region surrounded by the upper layer **153b** of the bank **153** with an ink jet apparatus or a nozzle-coating apparatus.

[0103] Even if the organic emitting material is sprayed or dropped on the upper layer **153b** because of a mis-alignment of the ink-jet apparatus or the nozzle-coating apparatus, the organic emitting material is concentrated into a center of the pixel region P because the material of the upper layer **153b** has a hydrophobic property. In addition, even if an excessive amount of the organic emitting material is sprayed or dropped, the organic emitting material does not flow over the upper layer **153b** due to the hydrophobic property of the upper layer **153b**.

[0104] Furthermore, since the lower layer **153a** has a thickness smaller than the organic emitting material layer **154**, the organic emitting material layer **154** is also formed on the lower layer **153a** even though the lower layer **153a** has a hydrophobic property.

[0105] Next, as shown in FIG. 9E, by performing a curing process, solvents and moisture in the organic emitting material layer **154** of FIG. 9D are removed such that the organic emitting layer **155** is formed in each pixel region P.

[0106] As mentioned above, since the organic emitting layer **155** has a uniform thickness in an entire surface of the effective pixel region SP of FIG. 8B, the OLED display device of the present invention has the improved aperture ratio. Namely, since the organic emitting layer **155** on a portion of the lower layer **153a** has a flat top surface with the organic emitting layer **155** in a center of the pixel region P, the effective emission area EA2 of FIG. 8B is enlarged in comparison to the effective emission area EA1 of FIG. 8A of the prior art OLED display device.

[0107] Here, the organic emitting layer **155** has a single-layered structure. Alternatively, to improve emission efficiency, the organic emitting layer **155** may have a multi-layered structure. For example, the organic emitting layer **155**

may include a hole injecting layer, a hole transporting layer, an emitting material layer, an electron transporting layer and an electron injecting layer stacked on the first electrode **150** as an anode. The organic emitting layer **155** may be a quadruple-layered structure of the hole transporting layer, the emitting material layer, the electron transporting layer and an electron injecting layer or a triple-layered structure of the hole transporting layer, the emitting material layer and the electron transporting layer.

[0108] Next, as shown in FIG. 9F, the second electrode **160** is formed on the organic emitting layer **155** by depositing a metallic material having a relatively low work function. The second electrode **160** is formed on an entire surface of a display region. The metallic material includes at least one of Al, Al alloy such as AlNd, Ag, Mg, Au and AlMg.

[0109] As explained above, the first electrode **150**, the organic emitting layer **155** and the second electrode **160** constitute the emitting diode E.

[0110] Next, as shown in FIG. 9G, after forming a seal pattern (not shown) on edges of the first substrate **110** or the second substrate **170**, the first and second substrates **110** and **170** are attached under a vacuum condition or an inert gas condition such that the OLED display device is fabricated. Alternatively, a paste seal (not shown), which is formed of a frit material, an organic insulating material or a polymer material, having transparent and adhesive properties is formed over an entire surface of the first substrate **110**, and then the first and second substrates **110** and **170** are attached. As explained above, instead of the second substrate **170**, an inorganic insulating film or an organic insulating film may be used for an encapsulation.

[0111] FIGS. 11A to 11F are cross-sectional views showing a fabricating process of an OLED display device according to a second embodiment of the present invention. Since other steps except for a step of forming a bank in the second embodiment are the same as those in the first embodiment, the explanation is focused on a bank having a double-layered structure with different widths, and explanations for other steps are omitted.

[0112] As shown in FIG. 11A, a switching TFT (not shown), a driving TFT DTr, a gate insulating layer **418**, a gate line (not shown), a data line **430**, a passivation layer **440**, and a first electrode **450** are formed on a first substrate **410**. A bank material layer **451** is formed on the first electrode **450** and the passivation layer **440**. For example, the bank material layer **451** may be formed by coating a polymer material having a hydrophobic property without a photosensitive property. A photoresist layer **495** is formed on the bank material layer **451** by applying photoresist.

[0113] Next, an exposing mask **498** including a transmitting region TA and a blocking region BA is disposed over the photoresist layer **495**, and an exposing process to the photoresist layer **495** is performed using the exposing mask **498**.

[0114] Here, the photoresist layer **495** is shown to have a negative type photosensitive property where an exposed portion of the photoresist layer **495** remains after a developing process. The transmitting region TA corresponds to edges of a pixel region P, and the blocking region BA corresponds to a center of the pixel region P.

[0115] In FIG. 11B, a first photoresist pattern **496** is formed by developing the photoresist layer **495** of FIG. 11A exposed to light through the exposing mask **498**. In this instance, an exposed portion of the photoresist layer **495** of FIG. 11A corresponding to the transmitting region TA of the exposing

mask **498** of FIG. **11A** remains to form the first photoresist pattern **496** having a first thickness the same as the photoresist layer **495** of FIG. **11A**, and a non-exposed portion of the photoresist layer **495** of FIG. **11A** corresponding to the blocking region BA of the exposing mask **498** of FIG. **11A** is removed by the developing process.

[0116] Next, in FIG. **11C**, a bank pattern **452** is formed under the first photoresist pattern **496** and **496** by removing the bank material layer **451** of FIG. **11B** exposed by the first photoresist pattern **496** through an etching process. The bank pattern **452** is disposed in the edge of the pixel region P and has a uniform thickness.

[0117] Next, in FIG. **11D**, a second photoresist pattern **496a** is formed by partially removing upper and side portions of the first photoresist pattern **496** of FIG. **11C** having the uniform thickness through an isotropic ashing process, and the bank pattern **152** is exposed outwards side surfaces of the second photoresist pattern **496a**. The second photoresist pattern **496a** has a second thickness smaller than the first thickness of the first photoresist pattern **496** of FIG. **11C** and a width smaller than that of the first photoresist pattern **496** of FIG. **11C**.

[0118] The exposed portion of the bank pattern **452** may have a width of 1 micrometer to 9 micrometers, and the width of the exposed portion of the bank pattern **452** may be controlled by adjusting ashing time or flow rates of ashing gases.

[0119] Meanwhile, residues of the bank material layer **451** of FIG. **11B** may remain after the etching process, and the residues may hinder a liquid phase organic emitting material from being spread because the bank material layer **451** of FIG. **11B** has the hydrophobic property. However, in the second embodiment of the present invention, the residues of the bank material layer **451** of FIG. **11B** can be completely removed through the isotropic ashing process, and the organic emitting material can be spread well when it is dropped.

[0120] Next, in FIG. **11E**, the bank pattern **452** of FIG. **11D** exposed by the second photoresist pattern **496a** is anisotropically dry-etched and partially removed using gases reacting with the bank pattern **452** of FIG. **11D** to thereby form a lower layer **453a** of a bank **453** such that the lower layer **453a** of the bank **453** has a thickness of 0.2 micrometers to 1.5 micrometers. At the same time, a portion of the bank pattern **452** of FIG. **11D**, which is disposed under the second photoresist pattern **296a** and is not anisotropically dry-etched, becomes an upper layer **453b** of the bank **453**.

[0121] Then, as shown in FIG. **11F**, the second photoresist pattern **496a** of FIG. **11E** is removed by performing a stripping process to thereby complete the bank **453** of a double-layered structure that includes the lower layer **453a** and the upper layer **453b** having the different widths. The width of the lower layer **453a** of the bank **453** is within a range of 0.2 micrometers to 1.5 micrometers. The upper layer **453b** of the bank **453** overlaps a center of the lower layer **453a** of the bank **453**.

[0122] Here, the width of the lower layer **453a** of the bank **453** exposed outwards side surfaces of the upper layer **453b** of the bank **453** may be 1 micrometer to 9 micrometers.

[0123] In the second embodiment of the present invention, the bank **453** including the lower layer **453a** and the upper layer **453b** of different widths is formed without use of an exposing mask, which includes a half-transmitting region and is relatively expensive. Therefore, the manufacturing costs are lowered.

[0124] Moreover, residues of the hydrophobic polymer material on the first electrode **450** can be completely removed during the ashing process of the first photoresist pattern, and thus the liquid phase organic emitting material can be spread well when the organic emitting layer is formed.

[0125] In the OLED display device of the invention, the effective emission area, where the organic emitting layer has a flat top surface, i.e., a uniform thickness, is increased due to the lower layer and the upper layer of the bank having different widths. As a result, the aperture ratio of the OLED display device is improved.

[0126] Furthermore, since an area of the organic emitting layer having the flat top surface increases in the pixel region, the brightness of the device is uniform, and display qualities are improved.

[0127] In addition, since the lower layer and the upper layer of the bank are formed in a single mask process, there are advantages in the production costs and the fabricating process.

[0128] Moreover, the uniformity in the thickness of the organic emitting layer is increased due to the lower layer of the bank, and the organic emitting layer is prevented from being degraded, thereby lengthening lifetime of the device.

[0129] It will be apparent to those skilled in the art that various modifications and variations can be made in the present invention without departing from the spirit or scope of the invention. Thus, it is intended that the present invention cover the modifications and variations of this invention provided they come within the scope of the appended claims and their equivalents.

What is claimed is:

1. An organic light emitting diode display device, comprising:
 - a substrate including a display region, wherein a plurality of pixel regions are defined in the display region;
 - a first electrode over the substrate and in each of the plurality of pixel regions;
 - a bank including a lower layer and an upper layer on the first electrode, the lower layer disposed on edges of the first electrode and having a first width and a first thickness, the upper layer disposed on the lower layer and having a second width smaller than the first width;
 - an organic emitting layer on the first electrode and a portion of the lower layer; and
 - a second electrode on the organic emitting layer and covering an entire surface of the display region.
2. The device according to claim 1, wherein the lower layer and the upper layer include a same material having a hydrophobic property.
3. The device according to claim 1, wherein the organic emitting layer on the portion of the lower layer has a flat top surface with the organic emitting layer on a center of the pixel region.
4. The device according to claim 1, wherein the organic emitting layer in a region surrounded by the lower layer has a uniform thickness.
5. The device according to claim 1, wherein the organic emitting layer has a second thickness larger than the first thickness.
6. The device according to claim 5, wherein the first thickness has a range within about 0.2 to 1.5 micrometers.

7. The device according to claim 1, wherein the upper layer completely overlaps the lower layer such that the lower layer protrudes from the upper layer by a third width.

8. The device according to claim 7, wherein the third width has a range within about 1 to 9 micrometers.

* * * * *

专利名称(译)	有机发光二极管显示装置及其制造方法		
公开(公告)号	US20150249117A1	公开(公告)日	2015-09-03
申请号	US14/643714	申请日	2015-03-10
[标]申请(专利权)人(译)	乐金显示有限公司		
申请(专利权)人(译)	LG DISPLAY CO. , LTD.		
当前申请(专利权)人(译)	LG DISPLAY CO. , LTD.		
[标]发明人	CHOI DAE JUNG LEE JAE KI YANG KI SOUB SEO HWANG UN JEON HONG MYEONG CHOI SEUNG RYUL LEE A RYOUNG KIM HAN HEE LEE GEUM YOUNG KIM KANG HYUN		
发明人	CHOI, DAE-JUNG LEE, JAE-KI YANG, KI-SOUB SEO, HWANG-UN JEON, HONG-MYEONG CHOI, SEUNG-RYUL LEE, A-RYOUNG KIM, HAN-HEE LEE, GEUM-YOUNG KIM, KANG-HYUN		
IPC分类号	H01L27/32 H01L51/50		
CPC分类号	H01L27/3246 H01L27/3262 H01L27/3248 H01L51/5012		
优先权	1020120134299 2012-11-26 KR		
其他公开文献	US9735211		
外部链接	Espacenet USPTO		

摘要(译)

一种有机发光二极管显示装置，包括：基板，包括显示区域，其中，多个像素区域限定在显示区域中；基板上方和多个像素区域中的每个像素区域中的第一电极；包括在第一电极上的下层和上层的堤，下层设置在第一电极的边缘上并具有第一宽度和第一厚度，上层设置在下层上并且具有小于第一宽度的第二宽度第一宽度；第一电极上的有机发光层和下层的一部分；第二电极位于有机发光层上并覆盖显示区域的整个表面。

